

S

SINGLE TUBE FLOW METERS

S STYLE

Model S single-tube flow meters pictured on this page are similar to *P* meters in design, employing the same interchangeable flow tubes, valves, and accessories. Likewise they may be panel or bench mounted.

Model S Flow Meter Shown.
With Optional Tripod Base and CV™ Valve

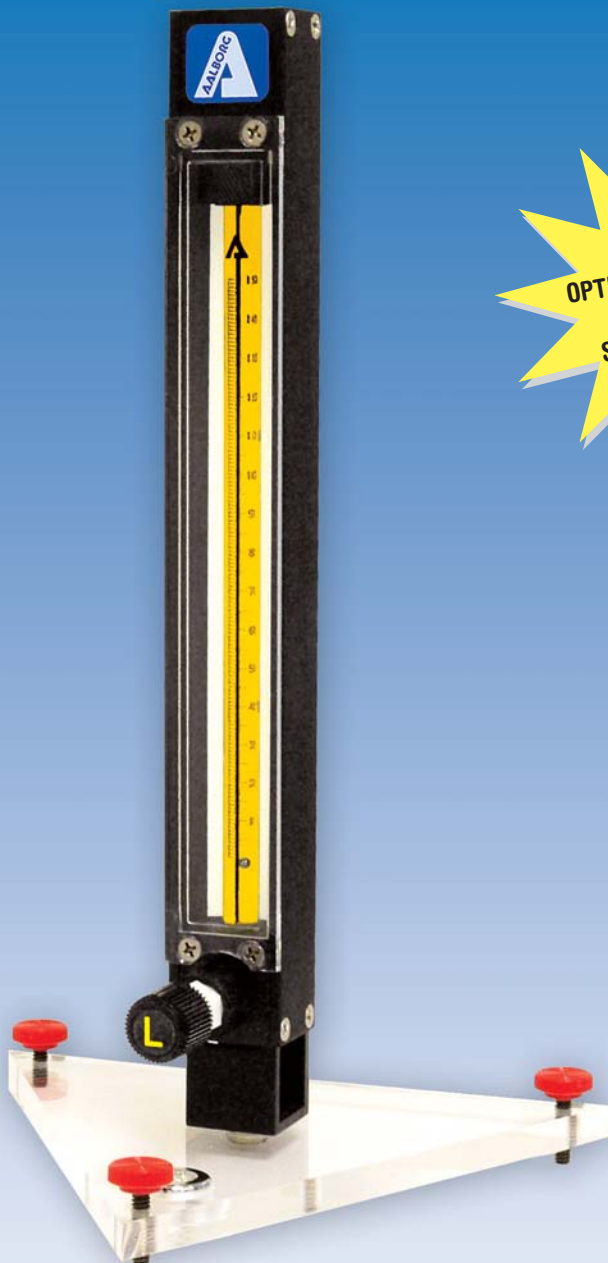

FOR
OPTICAL SENSOR
SWITCH
SEE PAGE 18

The important advantage of the *S* meter is convenience in applications, where frequent changing of tubes in meter cases is desired.

An example is when several flow tubes are used in conjunction with a single meter case, or when because of the nature of the fluid, periodic cleaning necessitates disassembly.

Aalborg's® exclusive TUBELOK™ design facilitates simple installation and replacement of tubes in mounting cases.

As a result of the “non-rotating” adapter feature, glass flow tubes are prevented from turning during the tightening phase of the assembly procedure.

design features

- ✓ TUBELOK™ design simplifies installation and replacement of tubes.
- ✓ Rib-guided or fluted metering tubes facilitate stable, accurate readings.
- ✓ Magnifier lens in front shield to enhance reading resolution.
- ✓ OPTIGRAD™ scales minimize parallax and eye fatigue.
- ✓ Simple means of panel mounting.
- ✓ Interchangeable flow tubes and floats.



BUILT-IN VALVES

Meters are available with built-in needle valves (CV™), high precision metering valves (MFV™) with “non-rising stems”, or with no valves. The higher cost of MFV™ valves is justified whenever high sensitivity control and resolution are desirable particularly in conjunction with metering tubes of very low flow rates. Generally, for gas metering it is recommended that valves are positioned at inlets (bottom) for liquids valves may be positioned either at inlets or outlets (top). For vacuum services, valves must be mounted at outlets. If unspecified at the time of ordering, meters will be shipped with valves mounted at the inlets.

SPECIFICATIONS	
STANDARD ACCURACY	±2% FS mm scales except 042 flow tubes. ±5% FS direct reading scales and 042 flow tubes.
CALIBRATED ACCURACY	±1% FS optional.
REPEATABILITY	±0.25%.
USEFUL FLOW RANGE	10:1 minimum with one float. Better than 20:1 with combination of two floats installed in meters.
MAXIMUM OPERATING PRESSURE	200 psig/13.8 bars.
MAXIMUM OPERATING TEMPERATURE	250 °F/ 121 °C.

** MATERIALS OF CONSTRUCTION	
FLOW TUBES	Heavy walled borosilicate glass.
FLOATS	Glass, Sapphire, 316 Stainless Steel, Carboloy® and Tantalum.
CHOICE OF MOUNTING FITTINGS IN CONTACT WITH FLUIDS	a) Aluminum, black anodized. b) Brass, chrome plated. c) 316 stainless steel.
SIDE PANELS	Aluminum, black anodized.
FRONT SHIELD	Lexan® with longitudinal magnifier lens for enhanced reading resolution.
BACK PLATE	1/8" thick white acrylics.
O-RINGS AND PACKING	Buna-N® o-rings in aluminum model. Viton® o-rings in stainless steel meters. OPTIONAL Viton®, PTFE/Kalrez® and EPR.
CONNECTIONS	1/8" NPT female inlet and outlet connections.
OPTIONAL	1/4" FNPT, hose and compression fittings are available.

**The selection of materials of construction, is the responsibility of the customer. The company accepts no liability.

DIMENSIONS FOR S STYLE METERS		
SCALE LENGTH (A)	ALL METERS	
	HEIGHT (H)	CENTER TO CENTER (D)
65mm	6.156	5.156
150mm	10.46	9.469

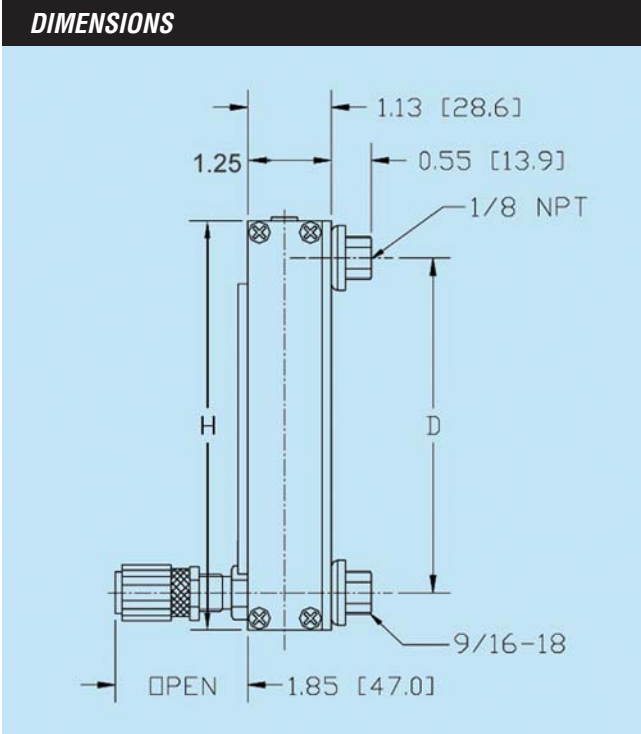
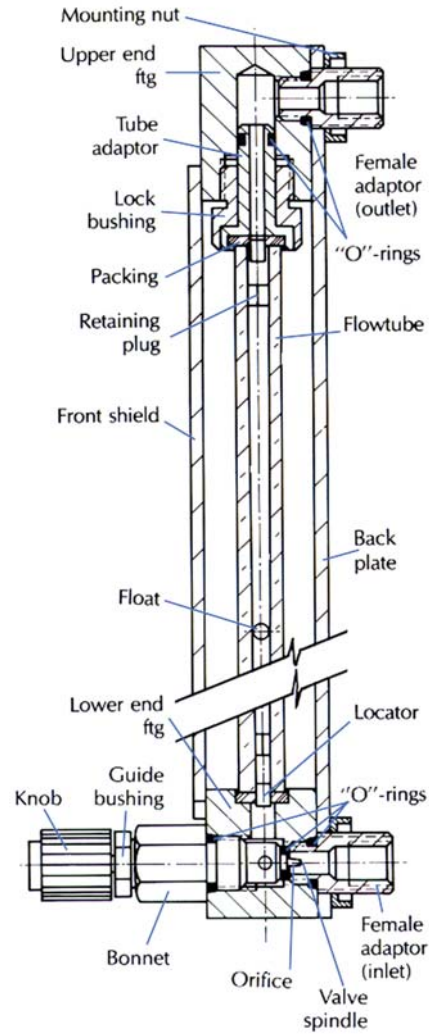

S

ORDERING INFORMATION MODEL S METERS

EXAMPLE

S	S STYLE METERS	
CODE	NUMBER OF CHANNELS	
1	SINGLE CHANNEL (ONE TUBE)	
CODE	SIZE	
6	65 mm	
1	150 mm	
CODE	MATERIAL	
A	ALUMINUM	
B	BRASS	
S	STAINLESS STEEL	
CODE	VALVE POSITION	
1	MFV (HIGH PRECISION) INLET	
3	NO VALVE	
4	CV (STANDARD CARTRIDGE) INLET	
5	MFV (HIGH PRECISION) OUTLET	
6	CV (STANDARD CARTRIDGE) OUTLET	
CODE	SEALS	
V	VITON® STD ON STAINLESS METERS	
B	BUNA® STD ON BRASS AND ALUMINUM	
E	EPR	
T	PTFE/KALREZ®	
CODE	FITTINGS	
A	1/8" FNPT	
B	1/4" FNPT	
C	1/8" HOSE NIPPLE	
D	1/4" HOSE NIPPLE	
E	1/8" COMPRESSION	
F	1/4" COMPRESSION	
H	VCR	
CODE	FITTINGS	
0	NONE	

S					—					—	TUBE
----------	--	--	--	--	---	--	--	--	--	---	-------------

Optional Accessories

TP1-Tripod for single channel meter.

Select tube from the following tables:

Tables 6 to 22. Pages 45 to 51.